



## ATMC SERIES

### Air-Thru Open Front Milk Coolers

#### STAINLESS INTERIOR & EXTERIOR MODELS

- ATMC-82SS
- ATMC-122SS
- ATMC-162SS

#### OPTIONAL WHITE INTERIOR & EXTERIOR MODELS

- ATMC-82
- ATMC-122
- ATMC-162

*Features the lowest entry point in the industry allowing easier access for small children and for stocking product*



ATMC-122SS

## FEATURES

### CONSTRUCTION

- Stainless steel interior and exterior
- Cabinet is insulated with foamed-in-place polyurethane
- Four easy roll swivel casters, two locking
- Epoxy-coated heavy-duty floor racks
- NSF-listed drain
- NSF-listed thermometer

### DOOR

- Door is insulated and has gaskets
- Chrome-plated hinges

- Key locks
- Fold-back door locks to safely stay open during use

### REFRIGERATION

- Air-thru evaporator
- Self-contained design
- Refrigerant: R-134a
- Easily accessed modular refrigeration system flush mounted on side of cooler with all components outside the milk storage compartment
- Large cooling capacity to maintain the required storage temperature

- Condensate evaporator
- Operating temperature: 38°F (3°C)

### WARRANTY

- Standard limited one year compressor, 18 month labor and one year limited parts

## CAPACITY

MODEL	CASES WITH CARTONS				LOOSE CARTON (WITHOUT CASES)	
	13" x 13" x 11"H		19" x 13" x 11"H		1/2 PINT	1 PINT
	CASES	CARTONS	CASES	CARTONS		
ATMC-82SS	8	352	4	288	864	432
ATMC-122SS	12	528	8	576	1368	684
ATMC-162SS	16	704	12	864	1800	900

## OPTIONS

- White interior and exterior
- Extended four year compressor warranty



# ATMC SERIES AIR-THRU OPEN FRONT MILK COOLERS

## TECHNICAL SPECIFICATIONS

MODEL	DIMENSIONS (in.)			DIMENSIONS (mm)			VOLTS	AMPS	UNIT H.P.	NO. OF FLOOR RACKS	CAP. CU. FT.	SHIP CU. FT.	SHIP WT. (LB/KG)
	L	D	H*	L	D	H*							
ATMC-82SS	47	33 <sup>1</sup> / <sub>8</sub>	37	1194	845	940	115	4.4	1/5	2	13.0	43.3	250/114
ATMC-122SS	61	33 <sup>1</sup> / <sub>8</sub>	37	1549	845	940	115	5.5	1/4	3	19.9	55.1	300/136
ATMC-162SS	75	33 <sup>1</sup> / <sub>8</sub>	37	1905	845	940	115	5.5	1/4	4	25.6	67.1	350/159

\*Height includes casters.

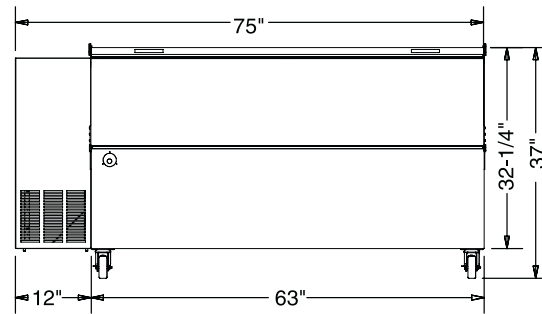
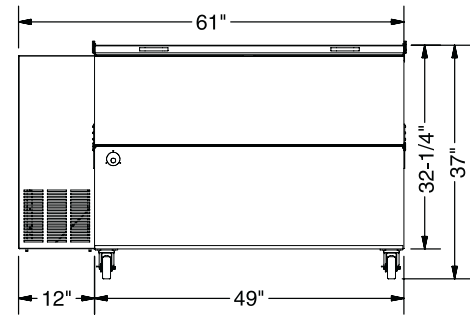
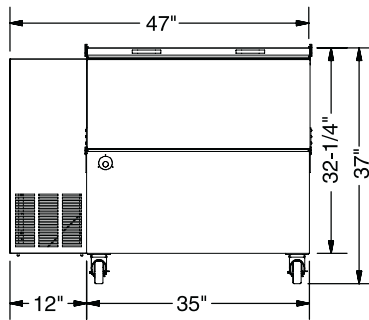
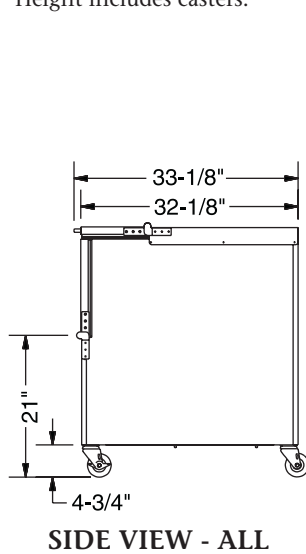

## LISTINGS



## HOOKUP

Via plug in, 8 foot long flexible three wire 16/3 cord with molded plug.



## BID SPECIFICATIONS

Item no. ATMC- \_\_\_\_\_ SS  
Provide \_\_\_\_\_ ( ) Air-Thru Open Front Milk Cooler(s), Master-Bilt model no. ATMC- \_\_\_\_\_ SS.

Milk cooler to be constructed of stainless steel on both interior and exterior and will be insulated with foamed-in-place polyurethane. It will be equipped with four swivel casters, two of which will be locking. Epoxy-coated heavy-duty floor

racks will also be standard as will an NSF-listed drain and thermometer.

Door to be insulated and will have gaskets and chrome-plated hinges. In addition, doors will fold back and lock to safely stay open during use and will feature key locks.

The refrigeration system will feature an exclusive air-thru, self-contained design and will have a condensate evaporator. The system will be a modular type flush mount-

ed on side of cooler with all components outside the milk storage compartment. The refrigerant will be R-134a and the operating temperature will be 38°F (3°C).

Cooler to have standard limited one year compressor, 18 month labor and one year limited parts warranty.

Cooler to be UL and C-UL listed, UL EPH classified as well as Energy Star and California Energy Code certified.

**NOTE:** Cabinet designed for optimum performance in air-conditioned area at 75°F ambient and 55% relative humidity. All specifications subject to change without notice.



908 Highway 15 North • New Albany, MS 38652  
PHONE: 800-647-1284 or 662-534-9061 • FAX: 800-232-3966 or 662-534-6049 • www.master-bilt.com

