



DC SERIES

Conventional Ice Cream Storage/Dipping Cabinets

MODELS

- | | |
|--------------------------------|---------------------------------|
| <input type="checkbox"/> DC-2S | <input type="checkbox"/> DC-8D |
| <input type="checkbox"/> DC-4S | <input type="checkbox"/> DC-10D |
| <input type="checkbox"/> DC-4D | <input type="checkbox"/> DC-12D |
| <input type="checkbox"/> DC-6D | |

FEATURES

CONSTRUCTION

- Seamless stainless steel top
- 24 gauge white painted galvanized steel cabinet
- Equipped with leveling legs to correct for unlevel flooring situations
- Floor drain with garden hose fitting
- Galvanized steel inner liner with cold wall evaporator
- Anti-condensate heaters under stainless top cap
- 2 1/4" foamed-in-place "zero ODP" urethane insulation

FINISH

- Baked-on white polyester enamel exterior finish with galvanized steel interior

LIDS

- Stainless steel
- Hinged with handles
- Gasket

REFRIGERATION

- Refrigerant:
 DC-12D R-404A
 All other models R-134a
- Self-contained, factory tested refrigeration system

- Force draft hermetic condensing unit (semi-hermetic unit on DC-12D with wire and tube condenser for low maintenance)
- Temperature range:
 10° to -10°F (-12° to -23°C)
- R-factor (insulation efficiency rating): 19.40

WARRANTY

- Standard limited four year extended compressor and one year limited parts and labor

OPTIONS

- Add suffix "SE" for all-stainless exterior
- Custom colors
- Lid locks
- Legs
- Casters
- Additional lids
- Load level shelves



DC SERIES

CONVENTIONAL ICE CREAM STORAGE/DIPPING CABINETS

TECHNICAL SPECIFICATIONS

MODEL	DIMENSIONS (in.)			DIMENSIONS (mm)			VOLTS	AMPS	UNIT H.P.	CAN CAP. DISPLAY/STORAGE*	CAP. CU. FT.	SHIP CU. FT.	SHIP WT. LB/KG
	L	D	H	L	D	H							
DC-2S	31 ⁷ / ₈	21 ¹ / ₈	34 ¹ / ₈	810	537	867	115	5.7	1/4	2/1	5.2	19.0	195/89
DC-4S	54	21 ¹ / ₈	34 ¹ / ₈	1372	537	867	115	5.7	1/4	5/4	11.0	36.0	280/127
DC-4D	30 ⁵ / ₈	30 ¹ / ₈	34 ¹ / ₈	778	765	867	115	5.7	1/4	5/2	7.6	27.0	220/100
DC-6D	43	30 ¹ / ₈	34 ¹ / ₈	1092	765	867	115	5.7	1/4	8/5	12.5	39.0	275/125
DC-8D	54	30 ¹ / ₈	34 ¹ / ₈	1372	765	867	115	7.3	1/3	11/8	17.3	47.0	365/164
DC-10D	66 ⁵ / ₈	30 ¹ / ₈	34 ¹ / ₈	1692	765	867	115	7.3	1/3	14/11	22.0	59.0	430/195
DC-12D	84 ⁵ / ₈	30 ¹ / ₈	34 ¹ / ₈	2149	765	867	115	7.5	1/3**	18/15	29.1	71.0	490/223

*Capacity in 3 gal. cans **Semi-hermetic compressor

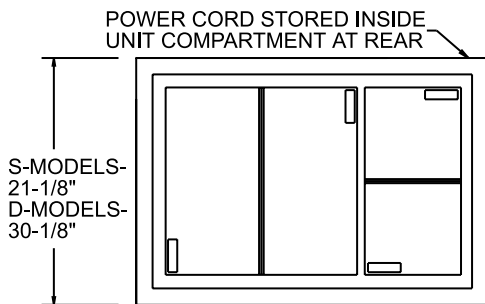

PLAN VIEW

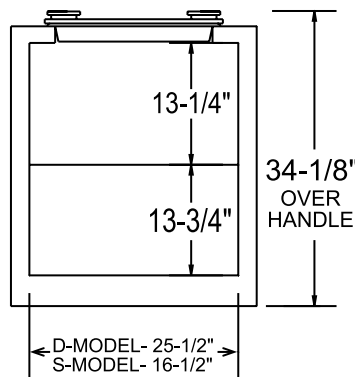

SIDE VIEW

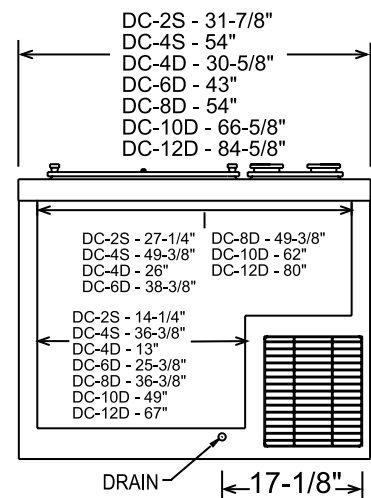

ELEVATION VIEW

LISTINGS



C-UL listing for all models except DC-12D.

HOOKUP

Via plug in, 9 foot long, flexible 3 wire 14/3 cord with molded plug. Ten amp 115V service is recommended.



BID SPECIFICATIONS

Item no. DC-_____

Provide _____ () Conventional Ice Cream Storage/Dipping Cabinet(s), Master-Bilt model DC-_____.

Cabinet to have flip lids, seamless stainless steel top, 24 gauge steel walls, galvanized steel inner liner with cold wall evaporator, anti-condensate heaters

under stainless steel top, 2¹/₄" foamed-in-place "zero ODP" urethane insulation and baked-on polyester enamel finish. Standard leveling legs provided to correct for unlevel flooring situations.

The refrigeration system will be self-contained. DC-12D will contain R-404A refrigerant and all other models will contain

R-134a. The temperature range will be 10° to -10°F (-12° to -23°C).

Cabinet to have standard limited four year extended compressor warranty and one year limited parts and labor warranty.

Cabinet to be UL, C-UL (on all except DC-12D) and NSF listed.

NOTE: Cabinet designed for optimum performance in air-conditioned area at 75°F ambient and 55% relative humidity. All specifications subject to change without notice.



908 Highway 15 North • New Albany, MS 38652
 PHONE: 800-647-1284 or 662-534-9061 • FAX: 800-232-3966 or 662-534-6049 • www.master-bilt.com

