



FIP-40

FIP-40 SERIES

Ice Cream And Novelty Display Merchandiser



MODEL
 FIP-40

FEATURES

STANDARD ELECTRONIC CONTROL

- Increases efficiency, reliability and convenience
- Allows user to easily monitor and adjust defrost functions from the panel interface on the front of the merchandiser
- Decreases service time and calls
- Eliminates room thermostat, defrost termination/fan delay control, defrost timer and digital thermometer or other temperature indicator



CONSTRUCTION

- 24 gauge painted steel interior and exterior
- Equipped with leveling legs to correct for unlevel flooring situations
- Stainless steel top serving deck
- Extra large, non-fogging front display window
- Four panes of tempered glass on front
- Removable backlit merchandising sign in stainless steel frame
- Two adjustable heavy-duty, white epoxy-coated, welded wire shelves
- Full length fluorescent lamp
- Automatic condensate evaporator
- Independent on/off light switch
- 2" foamed-in-place "zero ODP" urethane insulation

FINISH

- Sparkling white polyester enamel interior and exterior

DOORS

- Replaceable magnetic door gasket
- Foamed-in-place reversible rear door
- Self-closing

REFRIGERATION

- Self-contained, hermetic condensing unit
- Rear air intake and discharge
- Automatic defrost
- Refrigerant: R-404A
- Temperature range: 0° to -20°F (-18° to -29°C)
- R-factor (insulation efficiency rating): 17.24

WARRANTY

- Standard limited four year extended compressor and one year limited parts and labor

OPTIONS

- Custom colors
- Extra shelf



FIP-40 SERIES

ICE CREAM AND NOVELTY DISPLAY MERCHANDISER

TECHNICAL SPECIFICATIONS

MODEL	DIMENSIONS (in.)			DIMENSIONS (mm)			VOLTS	AMPS	UNIT H.P.	NO. OF SHELVES	STANDARD SHELF SIZE (in inches)	DISPLAY AREA SQ. FT.	CAP. CU. FT.	SHIP CU. FT.	SHIP WT. (LB/ KG)
	L	D	H	L	D	H									
FIP-40	40	31	50 ³ / ₁₆	1016	787	1270	115	13.6	3/4	2	19 x 35 ¹ / ₄	7.5	11.8	46.4	365/166

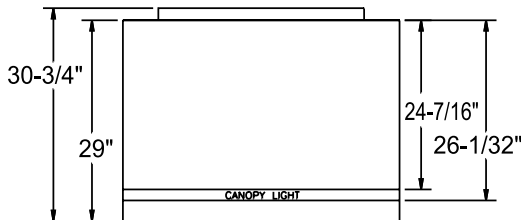

PLAN VIEW

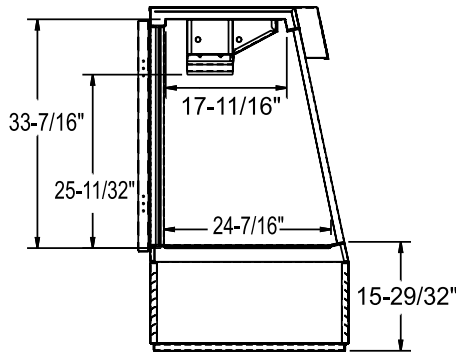

SIDE VIEW

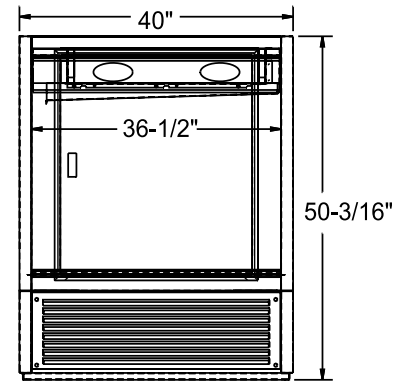

ELEVATION VIEW

LISTINGS



HOOKUP

Via plug in, 9 foot long, flexible 3 wire 14/3 cord with molded plug. Twenty amp service is required.



BID SPECIFICATIONS

Item no. FIP-40

Provide _____ ()

Low Temp Ice Cream and Novelty Display Merchandiser(s), Master-Bilt model no. FIP-40.

Merchandiser to be provided with electronic controller board monitoring system.

Construction features include stainless steel top serving deck, extra large non-fogging front display window, four panes of tempered front glass, backlit merchandising sign in stainless steel frame, adjustable

heavy-duty, white epoxy-coated welded wire shelves, and a full length fluorescent lamp. Standard leveling legs provided to correct for unlevel flooring situations.

Merchandiser to also have automatic condensate evaporator and independent on/off light switch. Cabinet to be foamed-in-place with "zero ODP" urethane insulation and to have a sparkling white polyester enamel interior and exterior. The doors are to be self-closing and have magnetic door gaskets. Rear doors are to be

foamed-in-place.

The refrigeration system is to have a self-contained, hermetic condensing unit using R-404A refrigerant. Refrigeration system will also contain a low maintenance bare tube condenser coil. The temperature range is to be 0° to -20°F (-18° to -29°C).

Merchandiser to have standard limited four year extended compressor warranty and one year limited parts and labor warranty. Merchandiser to be UL, C-UL and UL EPH listed.

NOTE: Cabinet designed for optimum performance in air-conditioned area at 75°F ambient and 55% relative humidity. All specifications subject to change without notice.



908 Highway 15 North • New Albany, MS 38652
PHONE: 800-647-1284 or 662-534-9061 • FAX: 800-232-3966 or 662-534-6049 • www.master-bilt.com

