



Note: Pumps, jars and spoons are not included in the base model.

FLR SERIES

Flavorail Ice Cream Dipping Cabinets

MODELS

- FLR-60
- FLR-80

FEATURES

CONSTRUCTION

- 20 gauge seamless stainless steel top
- 24 gauge steel cabinet
- Galvanized steel inner liner with copper tube wrap cold wall evaporator
- Anti-condensate heaters under stainless top cap
- 2 1/4" foamed-in-place "zero ODP" urethane insulation
- Equipped with leveling legs to correct for unlevel flooring situations
- Floor drain with standard garden hose fitting

FINISH

- Sparkling white polyester enamel exterior and galvanized interior

LIDS

- Stainless steel
- Hinged with handles
- Heavy-duty replaceable gasket

REFRIGERATION

- Refrigerant: R-134a
- Self-contained, slide-out, factory tested refrigeration system
- Forced draft hermetic condensing unit with wire and tube condenser for low maintenance

- Temperature range: 0° to -10°F (-18° to -23°C)
- R-factor (insulation efficiency rating): 19.40

WARRANTY

- Standard limited four year extended compressor and one year limited parts and labor

OPTIONS

- Add suffix "SE" for all stainless exterior
- Custom colors
- Pumps and jar assemblies
- Lid locking kit (less lock)
- Casters
- Individual pumps, jars, hinged jar lids and ladles



FLR SERIES

FLAVORAIL ICE CREAM DIPPING CABINETS

TECHNICAL SPECIFICATIONS

MODEL	DIMENSIONS (in.)			DIMENSIONS (mm)			VOLTS	AMPS	UNIT H.P.	CAN CAPACITY DISPLAY/STORAGE*	CAP. CU. FT.	SHIP CU. FT.	SHIP WT. LB/KG
	L	D	H	L	D	H							
FLR-60	43	30 ¹ / ₈	38 ¹ / ₄	1092	765	972	115	5.7	1/4	5/7	12.5	46	300/136
FLR-80	54	30 ¹ / ₈	38 ¹ / ₄	1372	765	972	115	7.3	1/3	6/11	16.8	57	340/155

*Capacity measured in 3 gallon cans.

FLR-60

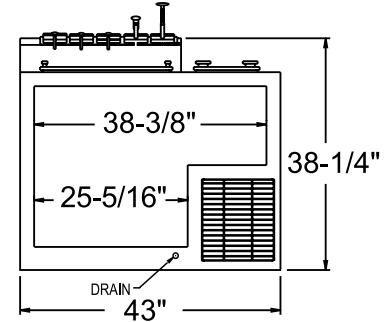
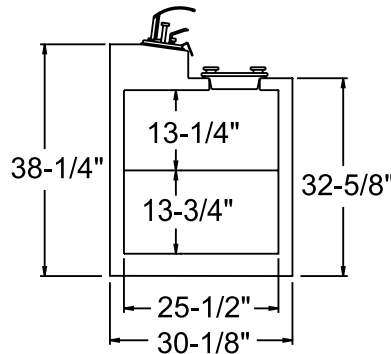
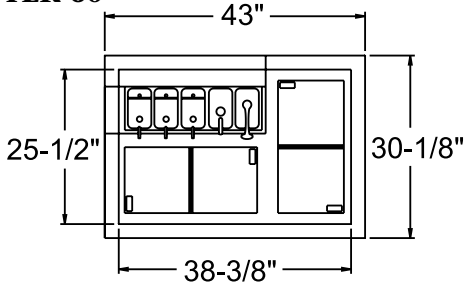

FLR-80

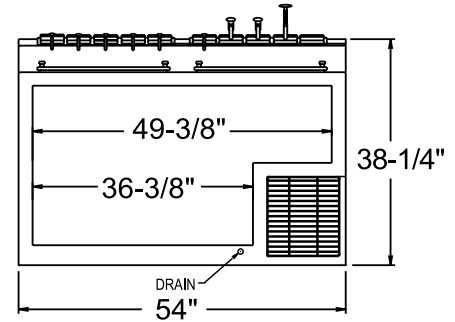
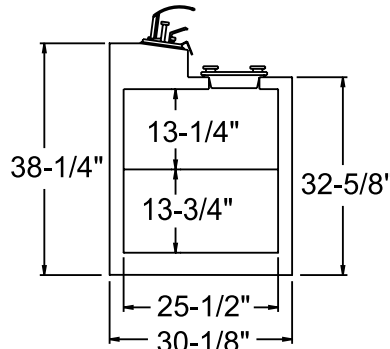
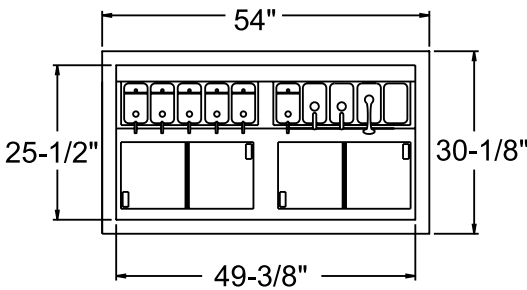

PLAN VIEW

SIDE VIEW

ELEVATION VIEW

Note: Pumps, jars and spoons are not included in the base model.

LISTINGS



HOOKUP

Via plug in, 8 foot long, flexible 3 wire 14/3 cord with molded plug. 15 amp service is recommended.



BID SPECIFICATIONS

Item no. FLR-_____
Provide _____ () Flavorail Ice Cream Dipping Cabinet(s), Master-Bilt model no. FLR-_____.
Cabinet to have anti-condensate heaters under stainless top cap, 2¹/₄" foamed-in-

place "zero ODP" urethane insulation and stainless steel lids hinged with handles. Standard leveling legs provided to correct for unlevel flooring situations.
The refrigeration system is to be self-contained and use R-134a refrigerant. The

temperature range will be 0° to -10°F (-18° to -23°C). Cabinet to have standard limited four year extended compressor warranty and one year limited parts and labor warranty. Cabinet to be UL, C-UL and NSF listed.

NOTE: Cabinet designed for optimum performance in air-conditioned area at 75°F ambient and 55% relative humidity. All specifications subject to change without notice.



908 Highway 15 North • New Albany, MS 38652
PHONE: 800-647-1284 or 662-534-9061 • FAX: 800-232-3966 or 662-534-6049 • www.master-bilt.com

