



GEL-12

GEL SERIES

Gelato Merchandisers

MODELS

- GEL-6
- GEL-9
- GEL-12

FEATURES

STANDARD ELECTRONIC CONTROL

- Allows user to easily monitor and adjust defrost functions from the panel interface on the front of the merchandiser
- Audible alarm
- Decreases service time and calls
- Eliminates room thermostat, defrost termination/fan delay control, defrost timer and digital thermometer or other temperature indicator



CONSTRUCTION

- Manufactured in the USA for faster service and parts and no dollar fluctuation
- Ideal for displaying gelato, ice cream, sorbet or Italian ice

- Concealed evaporator coils protect from spills
- GEL merchandisers ship assembled
- Designed to hold European five liter pans or can be configured for USA standard 1/3 size or three gallon tubs. **Pans are optional on all GEL models.**
- Allows two levels of pans: one for display and one underneath for storage
- Electric condensate evaporator pan **(requires a dedicated 15 amp, 120 volt circuit)**
- Standard power cord
- Rear air intake and front air discharge
- T8 electronic lighting

LIDS

- Front glass lid is top hinged for easy cleaning and access to cabinet interior. Lid stays in place at whatever point it's raised
- Sliding rear lids on back

REFRIGERATION SYSTEM

- Semi-hermetic compressor(s) standard
- Hot gas defrost

- GEL-6 refrigeration system contains one condensing unit, GEL-9 and GEL-12 contain two
- Temperature range: -5°F to 20°F (-21°C to -7°C)
- 2" thick walls with polyurethane insulation in the refrigeration compartment for dependable performance

FINISH

- Standard black finish with stainless steel front panel

WARRANTY

- Standard limited four year extended compressor and one year limited parts and labor

OPTIONS

- Casters
- Pans
- Legs
- Custom exterior colors (contact factory for pricing and availability)
- Laminates (contact factory for pricing and availability)



GEL SERIES GELATO MERCHANDISERS

TECHNICAL SPECIFICATIONS

MODEL	DIMENSIONS (in.)			DIMENSIONS (mm)			VOLTS*	AMPS**	UNIT H.P.	CAP. 5 LITER PANS	DISPLAY AREA SQ. FT.	CAP. CU. FT.	SHIP CU. FT.	SHIP WT. (LB/KG)
	L	D	H	L	D	H								
GEL-6	46 ⁵ / ₁₆	44 ¹ / ₂	53 ³ / ₈	1192	1130	1356	208-230	9.0	1	12	8.5	7.6	CONSULT FACTORY	900/409
GEL-9	65 ¹⁵ / ₁₆	44 ¹ / ₂	53 ³ / ₈	1675	1130	1356	208-230	13.1	***	18	12.5	10.8		1100/500
GEL-12	85 ¹ / ₂	44 ¹ / ₂	53 ³ / ₈	2172	1130	1356	208-230	13.8	***	24	16.4	14.2		1300/591

*Note: 208-230/60/1 also requires neutral and safety ground wire. **Electric condensate evaporator pan requires a dedicated 15 amp, 120 volt circuit. ***Refrigeration system contains two 1 HP compressors.

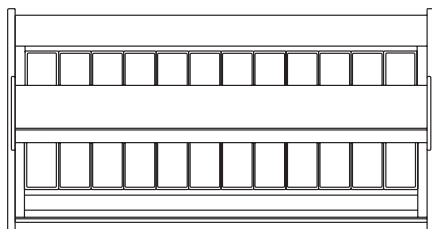

PLAN VIEW

GEL-6: 46-5/16"
GEL-9: 65-15/16"
GEL-12: 85-1/2"

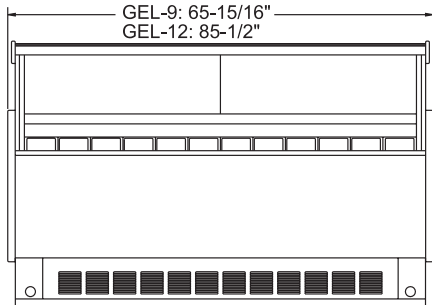

ELEVATION VIEW

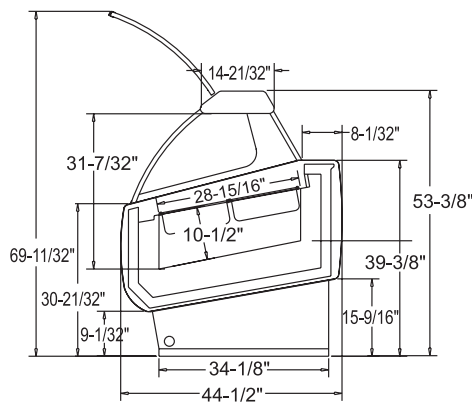

SIDE VIEW

LISTINGS



HOOKUP

Via plug in, 10 foot long flexible four wire 208-230v 14/4 cord with neutral and ground wires and plug. **Electric condensate evaporator pan requires a dedicated 15 amp, 120 volt circuit.**

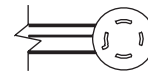

NEMA L14-20P

BID SPECIFICATIONS

Item no. GEL-_____
Provide _____ () Gelato Merchandiser(s), Master-Bilt model no. GEL-_____.

Merchandiser to be supplied assembled with top hinged front glass lid and sliding rear lids.

Merchandiser to have standard electronic controller eliminating the need for a room thermostat, defrost termination/fan delay

control, defrost timer and digital thermometer or other temperature indicator.

Other features will include electronic T8 interior lighting, standard power cord and concealed evaporator coils to protect from product spills.

The refrigeration system will contain one condensing unit in GEL-6 models and two units in GEL-9 and GEL-12. Condensing units will feature semi-hermetic compressors. Hot

gas defrost will be standard. In addition, the refrigeration compartment will contain 2" thick walls with polyurethane insulation for dependable performance. Temperature range will be -5°F to 20°F (-21°C to -7°C).

Merchandiser to have standard limited four year extended compressor warranty and one year limited parts and labor warranty. Merchandiser to be UL and C-UL listed and UL EPH classified.

NOTE: Cabinet designed for optimum performance in air-conditioned area at 75°F ambient and 55% relative humidity. All specifications subject to change without notice.



908 Highway 15 North • New Albany, MS 38652

PHONE: 800-647-1284 or 662-534-9061 • FAX: 800-232-3966 or 662-534-6049 • www.master-bilt.com

