



IM SERIES

Outdoor And Indoor Ice Merchandisers

OUTDOOR MODELS

- IM-38
- IM-60

INDOOR MODEL

- IM-45G

FEATURES

CONSTRUCTION

- 24 gauge steel panel construction with anti-sag support channels
- Air circulation channels on all four walls
- Floor racks for uniform air circulation
- Top mounted sign
- 2" foamed-in-place "zero ODP" polyurethane insulation
- Replaceable magnetic vinyl gaskets
- Outdoor cabinets only:
 - Padlock storage provision
 - Bold product messages on sides and front
- Indoor cabinet only:
 - Interior horizontal fluorescent lighting

FINISH

- Galvanized steel inner liner
- Outdoor cabinets only:
 - White enamel exterior

- Indoor cabinet only:
 - Mill-laminated, white vinyl exterior

DOORS

- Outdoor cabinets only:
 - Weather shield above doors
 - Combination door handle and lockplate
 - Self-closing, textured metal access doors
- Indoor cabinet only:
 - Triple pane, self-closing tempered glass door
 - Easy-grip, sculptured door handle

REFRIGERATION

- Self-contained, top mount refrigeration system
- Temperature range: 20° to 25°F (-7° to -4°C)
- R-factor (insulation efficiency rating): 17.24

- Thermostatically-controlled, automatic condensate evaporator (indoor cabinet only)

WARRANTY

- Standard limited four year extended compressor and one year limited parts and labor



IM SERIES

INDOOR AND OUTDOOR ICE MERCHANDISERS

TECHNICAL SPECIFICATIONS

MODEL	DIMENSIONS (in.)			DIMENSIONS (mm)			VOLTS	AMPS	UNIT H.P.	CAPACITY 8 LB. BAGS	SHIP CU. FT.	SHIP WT. LB/KG
	L	D	H	L	D	H						
IM-38	50 ¹ / ₂	35 ¹ / ₂	68 ¹ / ₂	1283	902	1740	115	5.7	1/4	125	90.3	340/155
IM-60	75	35 ¹ / ₂	68 ¹ / ₂	1905	902	1740	115	7.7	1/3	200	132.1	430/195
IM-45G*	48	30	76 ¹ / ₂	1219	762	1943	115	9.3	1/3	137	87.2	380/173

*Single glass door model for indoor use only.

IM-38

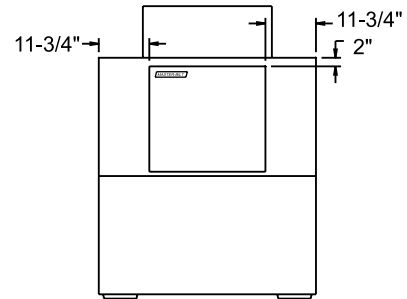
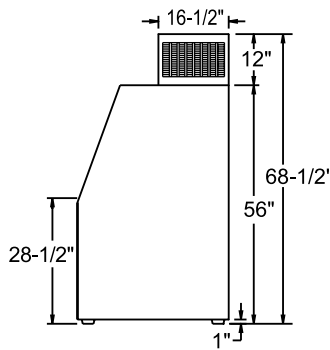
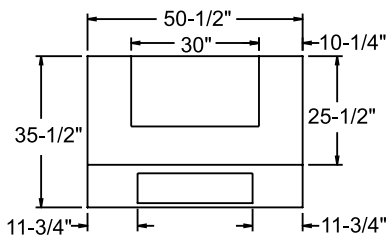

IM-60

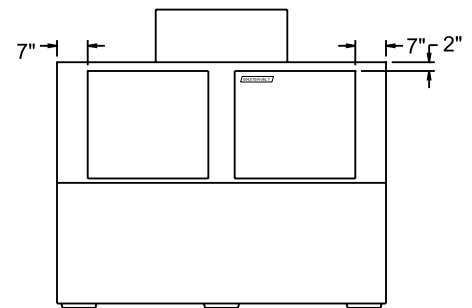
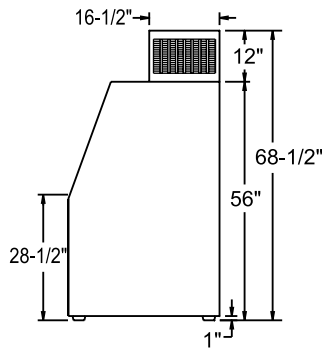
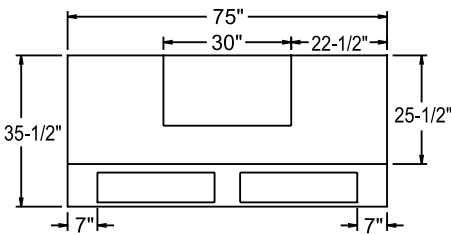

IM-45G INDOOR MODEL

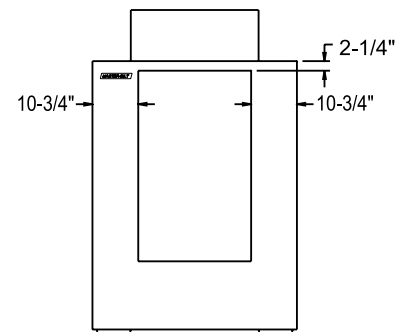
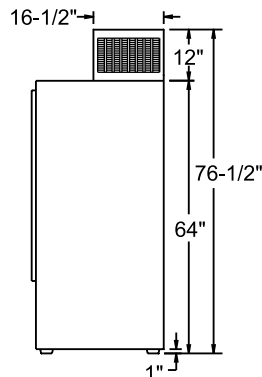
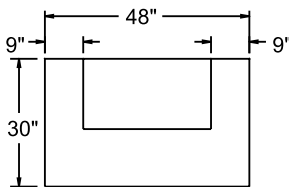

PLAN VIEW

SIDE VIEW

ELEVATION VIEW



NOTE: All specifications subject to change without notice.



908 Highway 15 North • New Albany, MS 38652
PHONE: 800-647-1284 or 662-534-9061 • FAX: 800-232-3966 or 662-534-6049 • www.master-bilt.com

