



MDT-06

## MDT SERIES

### Multi-deck Open Front Merchandisers

#### MODELS

- MDT-06
- MDT-08

## FEATURES

### STANDARD NIGHT CURTAINS AID IN ENERGY EFFICIENCY



#### CONSTRUCTION

- Can be used as either stand-alone units or combined in a modular endless design
- Mirrored interiors on end panels
- 24 gauge white painted galvanized steel interior and exterior
- Horizontal electronic lighting
- Drum thermometer
- Fans mounted on hinge panels for easy access
- 2" foamed-in-place "zero ODP" urethane insulation
- 22" deep solid shelving with standard price tag molding
- Number of shelves:
 

MDT-06 .....	12
MDT-08 .....	16
- Cabinet cubic feet:
 

MDT-06 .....	48.9
MDT-08 .....	65.3

#### REFRIGERATION

- Available with remote refrigeration system only
- Refrigerant: R-22
- Refrigeration lines and drain line connections designed to be easily accessed for installation purposes
- Temperature range: 34° to 41°F (1° to 5°C)
- R-factor (insulation efficiency rating): 17.24

#### WARRANTY

- One year limited parts

#### OPTIONS

- Special colors
- Lower light assembly



# MDT SERIES MULTI-DECK OPEN FRONT MERCHANDISERS

## TECHNICAL SPECIFICATIONS

OVERALL LENGTH*	OVERALL HEIGHT	OVERALL DEPTH	MODELS REQUIRED		CASE AMP DRAW			BTUH SINGLE @15°F SUCTION	BTUH RACK @15°F SUCTION	NORMAL AMBIENT CONDENSING UNIT UP TO 100°F†	HIGH AMBIENT CONDENSING UNIT 100° - 120°F†
					MDT-06	MDT-08	120V				
			LIGHTS	DEF. HTRS.			FANS				
6'0"	80 <sup>1</sup> / <sub>8</sub> "	37 <sup>1</sup> / <sub>2</sub> "	1		0.5	4.4	0.6	8,500	8,250	MHHX0190	MHHX0250
8'0"	80 <sup>1</sup> / <sub>8</sub> "	37 <sup>1</sup> / <sub>2</sub> "		1	0.5	6.1	0.9	10,640	10,320	MHHX0190	MHHX0250
12'0"	80 <sup>1</sup> / <sub>8</sub> "	37 <sup>1</sup> / <sub>2</sub> "	2		1.0	8.8	1.2	15,960	15,480	MHHX0350	MHHX0440
14'0"	80 <sup>1</sup> / <sub>8</sub> "	37 <sup>1</sup> / <sub>2</sub> "	1	1	1.0	10.5	1.5	18,620	18,060	MHHX0440	MHHX0440
16'0"	80 <sup>1</sup> / <sub>8</sub> "	37 <sup>1</sup> / <sub>2</sub> "		2	1.0	12.2	1.8	21,000	20,370	MHHX0440	MHHX0500
18'0"	80 <sup>1</sup> / <sub>8</sub> "	37 <sup>1</sup> / <sub>2</sub> "	3		1.5	13.2	1.8	23,940	23,220	MHHX0500	MHHX0500
20'0"	80 <sup>1</sup> / <sub>8</sub> "	37 <sup>1</sup> / <sub>2</sub> "	2	1	1.5	14.9	2.1	26,600	25,800	MHHX0500	MHHX0500
22'0"	80 <sup>1</sup> / <sub>8</sub> "	37 <sup>1</sup> / <sub>2</sub> "	1	2	1.5	16.6	2.4	29,260	28,380	MHHX0500	MHHX0500
24'0"	80 <sup>1</sup> / <sub>8</sub> "	37 <sup>1</sup> / <sub>2</sub> "		3	1.5	18.3	2.7	31,920	30,960	MHHX0500	MHHX0500
26'0"	80 <sup>1</sup> / <sub>8</sub> "	37 <sup>1</sup> / <sub>2</sub> "	3	1	2.0	19.3	2.7	34,580	33,540	CONSULT FACTORY	
28'0"	80 <sup>1</sup> / <sub>8</sub> "	37 <sup>1</sup> / <sub>2</sub> "	2	2	2.0	21.0	3.0	37,240	36,120		
30'0"	80 <sup>1</sup> / <sub>8</sub> "	37 <sup>1</sup> / <sub>2</sub> "	1	3	2.0	22.7	3.3	39,900	38,700		

\*Total overall length without ends. Add 2" for each end. †Add suffix "B" for single phase unit or "C" for three phase.

**NOTE: BTUH LOAD AND UNIT SIZES ARE BASED ON A 75°F, 55% RELATIVE HUMIDITY (MAXIMUM) STORE.**

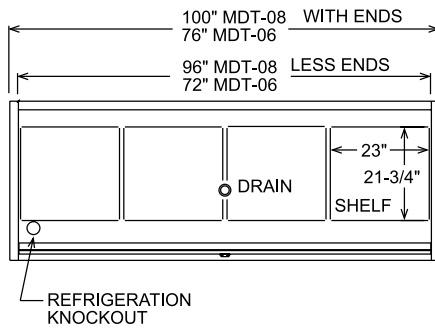

PLAN VIEW

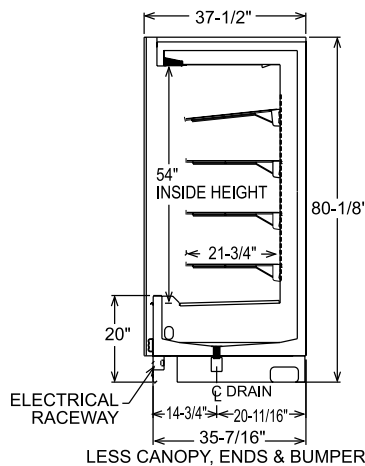

SIDE VIEW

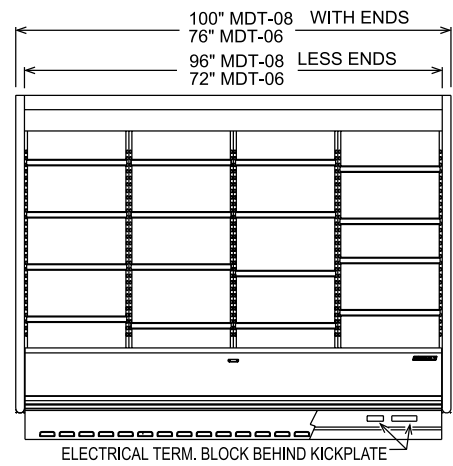

ELEVATION VIEW

## LISTINGS



## HOOKUP

Hardwire, remote refrigeration.

## BID SPECIFICATIONS

Item no. MDT-\_\_\_\_\_  
Provide \_\_\_\_\_ ( ) Multi-deck Open Front Merchandiser(s), Master-Bilt model no. MDT-\_\_\_\_\_.

Merchandiser to be constructed of 24 gauge white painted galvanized steel interior and exterior with 2" foamed-in-place "zero ODP" urethane insulation. Merchandiser may

be used as either a stand-alone unit or combined in a modular endless design. Merchandiser supplied with mirrored interiors on end panels, horizontal electronic lighting, drum thermometer and 22" deep solid shelving with standard price tag molding. Evaporator fans will be mounted on hinge panels for easy access.

Merchandiser available with remote refrigeration system only.

System uses R-22 refrigerant. Refrigeration lines and drain line connections designed to be easily accessed for installation purposes. The temperature range will be 34° to 41°F (1° to 5°C).

Merchandiser to be UL and C-UL listed and UL EPH classified. Merchandiser to have one year limited parts warranty.

**NOTE: Cabinet designed for optimum performance in air-conditioned area at 75°F ambient and 55% relative humidity. All specifications subject to change without notice.**



908 Highway 15 North • New Albany, MS 38652  
PHONE: 800-647-1284 or 662-534-9061 • FAX: 800-232-3966 or 662-534-6049 • www.master-bilt.com

