

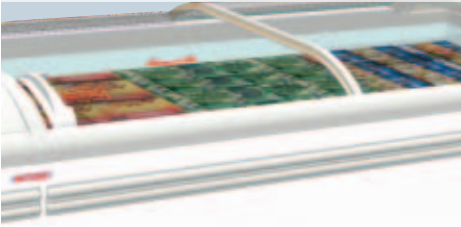

MALTA



New
The »360 SHOP
AROUND« sales star

- increased visibility from all sides
- higher impact on shoppers
- new highlight within store area





Your new innovative »impulse merchandiser« is accessible from all sides and provides an easy view. The strong design and absolute functionality make it the perfect all-round unit for attractive product presentation.



Model	MALTA
External dimensions (W x H x D)	72.87 x 32.80 x 33.66 inch
Internal dimensions (W x H x D)	67.72 x 25.79 x 28.35 inch
Net volume	19.46 cu.ft.
Net weight	251 lb
Internal temperature regulation range	0 °F to -9 °F
Nominal power input incl. light	500 W
Load limit height	19.29 inch

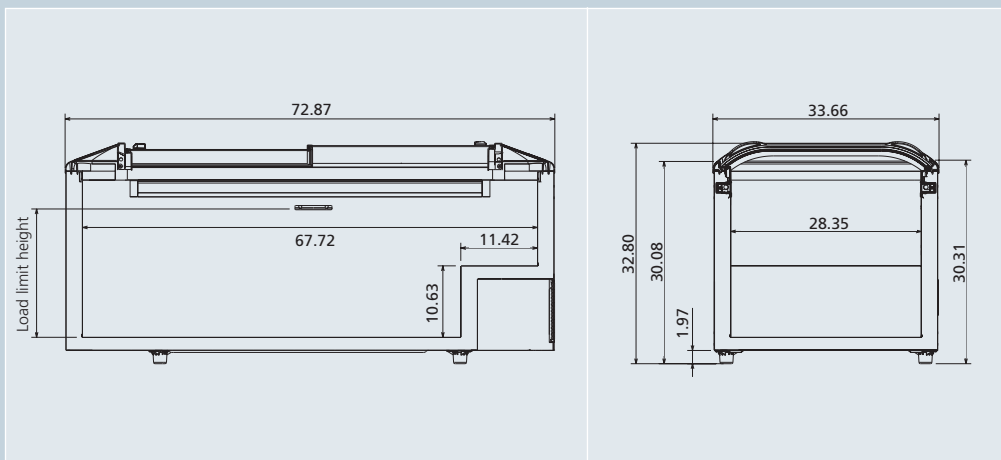

Subject to technical modifications and typographical errors. Version: 04/2005

MALTA