

NOR-LAKE[®] SCIENTIFIC

SELECT[™] PASS-THRU LABORATORY AND PHARMACY REFRIGERATORS

Designed to meet the demanding requirements for scientific and laboratory research. Advanced engineered design incorporates the latest in cabinet, refrigeration, temperature control and monitoring features. Provides energy efficient, convenient, safe and reliable performance for optimal storage temperature environments necessary for a wide range of life science, pharmacy, biological, medical, clinical, and industrial applications.

Standard Product Features:

- Digital 4x20 character LCD display microprocessor temperature controller
- Audible and visual Hi/Lo temperature alarm
- Adjustable control range from 2°C to 10°C factory preset at 4°C
- Remote alarm contacts
- Continuous product temperature display
- 3 sensor system, 2 product, 1 air
- Power supply switch
- Door ajar alarm, audible and visual
- 2 to 10 volt DC output for product temperature (selectable to air temperature)
- Password protection- set-points and factory settings
- 100 event alarm logging
- Integrated Hi/Lo product temperature alarm test
- Digital calibration air and product
- Real time clock with date and time display
- Door opening counter with 24 hour automatic reset
- Adjustable alarm beep or constant on (key pad selectable)
- Alarm volume adjustable
- Low battery test switch with buzzer
- Fan motor run time monitor
- Defrost time monitor
- Condenser/compressor run time monitor
- Sensor failure alarm
- Exterior cabinet front, sides and back are painted white
- Exterior cabinet top and bottom are galvanized steel
- Interior cabinet liner and door panel are painted white
- Cabinet and solid doors are foamed-in-place with CFC Free high density polyurethane foam insulation
- Glass door(s) on applicable models are full size, double pane
- Glass door(s) are standard on all WWF suffix models and WWG suffix models (controller side)
- Solid door(s) on applicable models are full size
- Solid door(s) are standard on WWW suffix models and WWG suffix models (non-controller side)
- Heavy duty door pivot hinges
- Pull door handles
- Magnetic door gaskets
- Centered key door lock(s) (2 keys)
- Four casters on two and four door models (2 locking), Six casters (3 locking) on six door models
- 3 coated wire shelves per door section
- Interior light, switch activated
- Air cooled condensing unit
- Top mounted forced air refrigeration system
- Automatic defrost and condensate evaporation
- Sensor access port, 1" diameter
- Warranties: 24 month parts and labor, 5 year compressor (US and Canada) 18 months parts (International)
- UL/CUL listed
- Tested to meet the Maximum Daily Energy Consumption Requirements (KWhr/day) as defined by the California Energy Commission Appliance Efficiency Regulations and the ENERGYSTAR[®] Program Requirements for Commercial Refrigerators and Freezers.

Optional Features:

- Extra shelf
- Legs 6" in lieu of casters
- Reverse hinge door(s)
- Stainless steel interior
- Stainless steel exterior
- Stainless steel drawer (maximum 8 per door)
- Wire basket drawer (maximum 6 per door)
- Internal electrical outlet
- Access port 2" sleeve with cover
- Temperature chart recorder with chart paper
- 4-20ma output for product temperature (selectable to air temperature)
- RS-485 digital communications port (MODBUS-RTU)
- Ethernet 10 baseT (HTTP) control.monitoring web card
- Secure Guard II Lock ProxKey (Factory Installed)
- Secure Guard II MagKey (Factory Installed)
- Secure Guard II Lock Software
- Seismic mounting kit
- Export crating

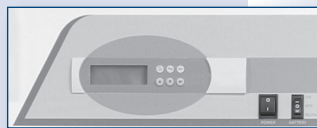

NSSP524 WWG



NSSP242WWG



NSSP524 WWG



NSSP806WWG

NORLAKE SCIENTIFIC



Committed to our environment



Nor-Lake, Inc.
Registered to ISO 9001:2008
File No. 10001816

NOR-LAKE SCIENTIFIC
A Division of
NOR-LAKE, INCORPORATED
727 Second Street
P.O. Box 248
Hudson, Wisconsin 54016
800-477-5253
715-386-2323
800-388-5253 PARTS
715-386-4290 FAX
www.norlakescientific.com

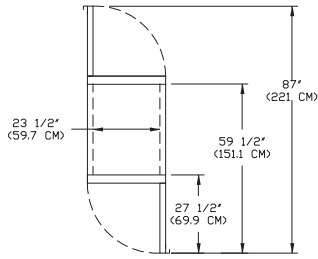

NSSP242WW_/_

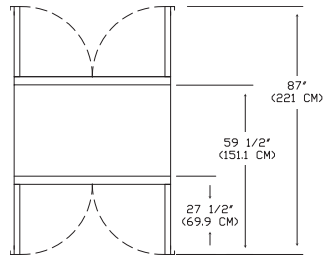

NSSP524WW_/_

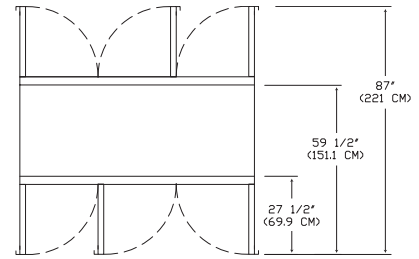

NSSP806WW_/_

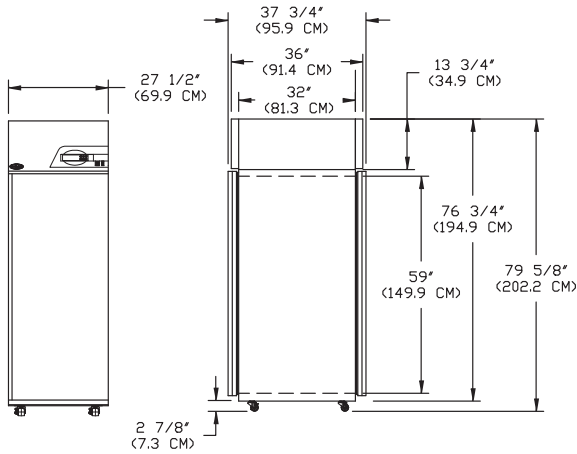

NSSP242WW_/_

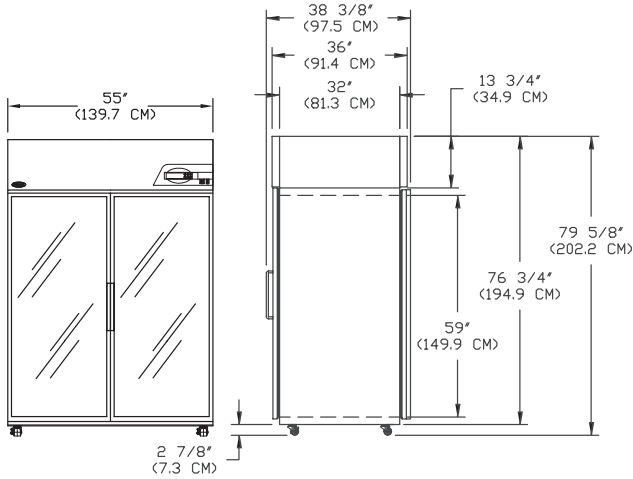

NSSP524WW_/_

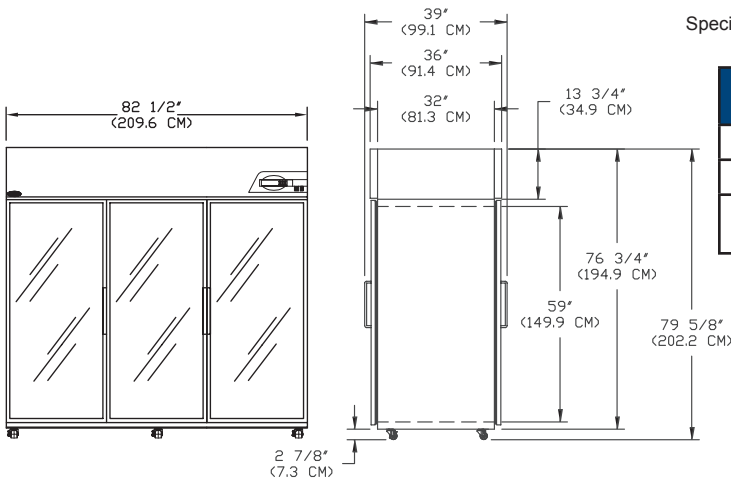

NSSP806WW_/_

FRONT

SIDE

SPECIFICATIONS

	<i>NSSP242WWF/0</i>	<i>NSSP524WWF/0</i>	<i>NSSP806WWF/0</i>
All Glass Doors	<i>NSSP242WWF/4</i>	<i>NSSP524WWF/4</i>	<i>NSSP806WWF/4</i>
	<i>NSSP242WWF/5</i>	<i>NSSP524WWF/5</i>	<i>NSSP806WWF/5</i>
	<i>NSSP242WWG/0</i>	<i>NSSP524WWG/0</i>	<i>NSSP806WWG/0</i>
Glass/Solid Doors	<i>NSSP242WWG/4</i>	<i>NSSP524WWG/4</i>	<i>NSSP806WWG/4</i>
	<i>NSSP242WWG/5</i>	<i>NSSP524WWG/5</i>	<i>NSSP806WWG/5</i>
	<i>NSSP242WWW/0</i>	<i>NSSP524WWW/0</i>	<i>NSSP806WWW/0</i>
All Solid Doors	<i>NSSP242WWW/4</i>	<i>NSSP524WWW/4</i>	<i>NSSP806WWW/4</i>
	<i>NSSP242WWW/5</i>	<i>NSSP524WWW/5</i>	<i>NSSP806WWW/5</i>
	<i>Crated Height (in) (cm)</i>	83-3/4" (212)	83-3/4" (212)
<i>Crated Width (in) (cm)</i>	38" (96)	59" (149)	86" (218)
<i>Crated Depth (in) (cm)</i>	40" (101)	40" (101)	38" (96)
<i>Crated Weight (lbs) (kg)</i>	375 (170)	590 (268)	805 (365)
<i>Interior Height (in) (cm)</i>	59" (149)	59" (149)	59" (149)
<i>Interior Width (in) (cm)</i>	23-1/2" (59)	51" (129)	78-1/2" (199)
<i>Interior Depth (in) (cm)</i>	30" (76)	30" (76)	30" (76)
<i>Overall Height (in) (cm)</i>	79-5/8" (202)	79-5/8" (202)	79-5/8" (202)
<i>Overall Width (in) (cm)</i>	27-1/2" (69)	55" (139)	82-1/2" (209)
<i>Overall Depth (in) (cm)</i>	34-7/8" (88)	34-7/8" (88)	35-7/8" (88)
<i>Gross Cubage (ft.3) (m3)</i>	24.0 (0.6)	52.0 (1.4)	80.0 (2.2)
<i>Shelf Area (sq. ft.) (m²)</i>	12.83 (1.1)	28.6 (2.6)	42.84 (3.9)
<i>Number of Shelves</i>	3	6	9
<i>Number of Casters</i>	4	4	6
<i>Condensing Unit Size</i>	1/2HP	3/4HP	1HP
<i>Refrigerant</i>	R-134a	R-134a	R-134a
<i>Maximum Fuse Size</i>	15 AMPS	15 AMPS	15 AMPS
<i>Total Amp Draw /0</i>	8.6	10.7	10.4
<i>Total Amp Draw /4</i>		Consult Factory	
<i>Total Amp Draw /5</i>	3.2	4.2	8.1

Specifications subject to change without notice.

Voltage Model Suffix Code	Voltage Description	NEMA Plug	NEMA Receptacle
/0	115V, 1PH, 60HZ	5-15P	5-15R
/4	208/230, 1PH, 60HZ	6-15P	6-15R
/5	230V, 1PH, 50HZ	Power Inlet (IEC 60320) Module	Cord Supplied Locally

NORLAKE SCIENTIFIC

Revision Date: 6/09
 ©2009 NOR-LAKE, INC.
 Printed in the U.S.A.
 Part Number: 143228

