

QMVM SERIES

Quantum Series Medium Temp Vertical Open Display Merchandisers

MODELS

- QMVM-36
- QMVM-48
- QMVM-72

FEATURES

STANDARD ELECTRONIC CONTROL

- Increases efficiency, reliability and convenience
- Allows user to easily monitor and adjust defrost functions from the panel interface on the front of the merchandiser
- Decreases service time and calls
- Eliminates room thermostat, defrost termination/fan delay control, defrost timer and digital thermometer or other temperature indicator



CONSTRUCTION

- 24 gauge galvanized steel exterior and interior
- Shelves adjustable in 1" increments
- Three lighted tiers of two-position shelving standard

- Perforated interior back wall and top for better air flow
- Price tag molding
- Electric defrost
- 1" black vinyl front bumper guard
- 2" foamed-in-place "low ODP" urethane insulation
- Easily accessible electrical enclosure

FINISH

- White enamel interior and exterior
- Stainless steel floor pans (removable for easy service)

REFRIGERATION

- Refrigerant: R-404A
- Front air intake and rear air discharge
- Self-contained, bottom mount refrigeration system
- Temperature range: 34° to 41°F (1° to 5°C)
- R-factor (insulation efficiency rating): 17.24
- **Drain plumbing hookup recommended. Condensate pan available if there is no access to drain plumbing. Condensate pan must be field**

installed and requires a dedicated 15 amp, 120 volt circuit.

WARRANTY

- Standard limited four year extended compressor and one year limited parts and labor

OPTIONS

- Add suffix "R" for remote system (QMVM-48 and -72 only)
- Custom exterior colors
- Condensate evaporator drain pan
NOTE: Must be field installed and requires a dedicated 15A, 120v circuit.
- Condensate pump
- Product hooks
- Extra shelves (lighted)
- Extra shelves (non-lighted)
- Custom bumper colors: Black (standard), blue, brown, green, red, white
- Locking metal night curtain (less locks)



QMVM SERIES

QUANTUM SERIES MEDIUM TEMP VERTICAL OPEN DISPLAY MERCHANDISERS

TECHNICAL SPECIFICATIONS

MODEL	DIMENSIONS (in.)			DIMENSIONS (mm)			VOLTS	AMPS*	UNIT H.P.	NO. OF SHELVES	STANDARD SHELF WIDTH** (in inches)	CAP. CU. FT.	SHIP CU. FT.	SHIP WT. LB/KG
	L	D	H	L	D	H								
QMVM-36	36	31	81	914	787	2057	115/208-230	1.7/11.5	1	3	31 ¹ / ₈	13.6	89.0	525/239
QMVM-48	48	31	81	1219	787	2057	115/208-230	2.4/13.1	1	3	43 ¹ / ₈	20.4	107.0	640/291
QMVM-72	72	31	81	1829	787	2057	115/208-230	3.7/13.7	1 ¹ / ₂	6	33 ¹ / ₁₆	31.5	152.0	860/391

*If condensate evaporator pan accessory is used, it must be field installed and requires a dedicated 15 amp, 120 volt circuit.

**All models contain three standard shelf depths: 10", 12" and 14".

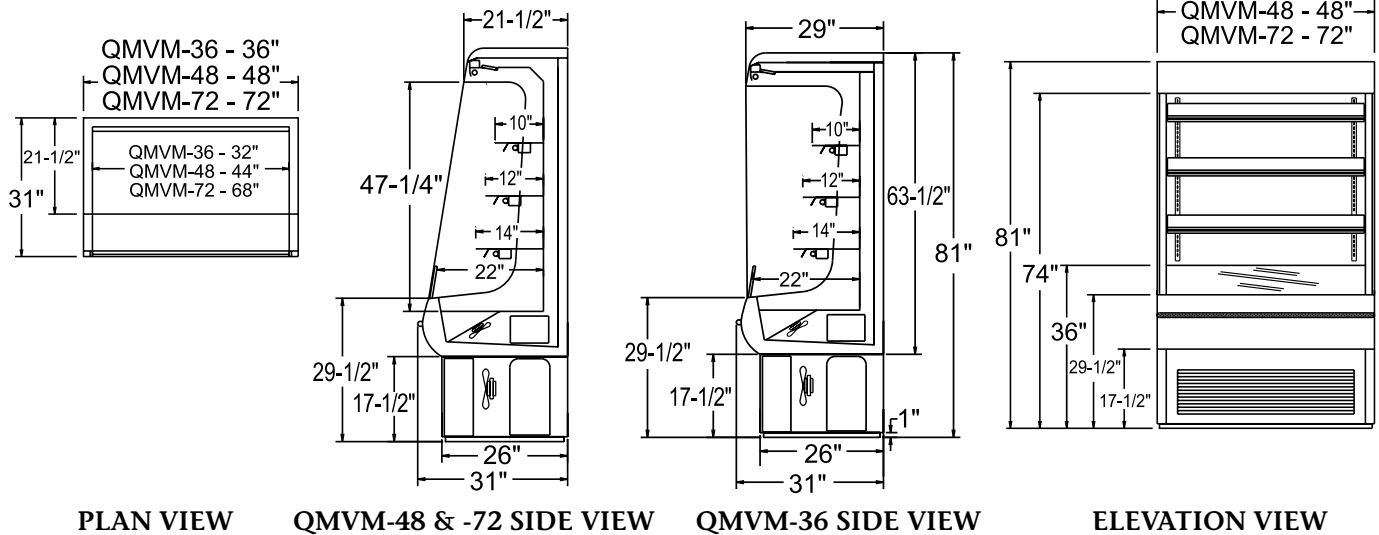

LISTINGS



HOOKUP

Electrical hookup: Hardwire
Plumbing hookup: Requires connection to customer's drain

RECOMMENDED OPERATING CONDITIONS

- Merchandisers designed to hold product in the 34° to 41°F (1° to 5°C) range
- Designed to operate in air-conditioned stores where the maximum temperature is 75°F and the maximum relative humidity is 55%
- Should not be installed in direct sunlight
- Should not be installed near HVAC vents, fans or doorways that will disrupt airflow and compromise the function of the air screen inside the case
- Bottom shelf should not be loaded such that the front air intake is obstructed
- Floor drain should be properly trapped
- Factory installed controls should not be altered, removed or replaced without consent of the factory
- Product must not be displayed in the cold air curtain

BID SPECIFICATIONS

Item no. QMVM-_____
Provide _____ () Quantum Series Medium Temp Vertical Open Display Merchandiser(s), Master-Bilt model no. QMVM-_____.
Merchandiser to have standard electronic controller eliminating the need for a room thermostat, defrost termination/fan delay control, defrost timer and digital thermom-

eter or other temperature indicator.
Other features will include adjustable two-position shelves, independent shelf lighting, perforated interior back wall, electric defrost, 1" vinyl front bumper guard and 2" foamed-in-place "low ODP" urethane insulation.
The refrigeration system is to be self-contained, have a front condenser air intake and

rear air discharge and use R-404A refrigerant. The temperature range will be 34° to 41°F (1° to 5°C).
Merchandiser to have standard limited four year extended compressor warranty and one year limited parts and labor warranty.
Merchandiser to be UL and C-UL listed and UL EPH classified.



908 Highway 15 North • New Albany, MS 38652
PHONE: 800-647-1284 or 662-534-9061 • FAX: 800-232-3966 or 662-534-6049 • www.master-bilt.com

All specifications subject to change without notice.