

# SN-Series 650 Nugget Ice Machine



**Manitowoc**



SN-Series 650  
Ice Machine on B-420 Bin



SN-Series 650  
Ice Machine  
on MDH-302  
Dispenser

- Up to 732 lbs. (332 kgs.) daily ice production
- Only 22" (55.88 cm) wide
- Dimensions of nugget ice are approximately 3/10" x 3/10" x 1/2" (8 x 8 x 12 mm)
- SoftQube™ nugget Ice provides a softer, chewable texture while still providing maximum cooling effect
- Manitowoc's patented cleaning technology manages the cleaning process from start to finish
- Evaporator is designed for maximum quality and operating life
- Warranty  
2-year parts and labor coverage on all components. Additional 3-year (5-year total) parts coverage on ice machine compressor



ISO 9001:2000  
Quality System  
Certified

**America's #1 Selling Ice Machine**

Cube, Nugget & Flake Ice Machines • Ice Storage Bins • Ice Dispensers

**Manitowoc**  
Foodservice Group

# SN-Series 650 Nugget Ice Machine

## Space-Saving Designs



	SN-650 B-420	SN-650 B-400
Height	71.50" 194.31 cm	65.00" 165.10 cm
Width	22.00" 55.88 cm	30.00" 76.20 cm
Depth	34.00" 86.30 cm	34.00" 86.30 cm
Bin Storage	310 lbs. 141 kgs.	310 lbs. 141 kgs.

B-400 requires K-00141 adapter.

Height includes adjustable bin legs 6.00" to 7.00", (15.24 to 17.78 cm) set at 6.00" (15.24 cm).

Model	Ice shape	Ice production 24 hours Based on Air/Water Temp.				Power kWh/100 lbs.
		70°/50°F		90°/70°F		
SN-0658A	nugget	732 lbs.	332 kgs.	564 lbs.	256 kgs.	5.0
SN-0659W	nugget	690 lbs.	313 kgs.	595 lbs.	270 kgs.	4.4
SN-0658N	nugget	655 lbs.	297 kgs.	581 lbs.	264 kgs.	5.5
Water usage/100 lbs./45.4 kgs. of ice						
Potable Water: 12 gallons, 45.4 liters • Water-cooled Condenser: 100 gallons, 379 liters						

Order ice storage bin separately. "A", "W" or "N" following model number indicates

"Air", "Water" or "Remote" condensing unit. Use JC-0495A condenser unit and RM tubing.

\*Will not accept AuCS accessory.

Test conditions are 90°F/32°C air, 70°F/21°C water, and 30 ± 3 psig water inlet pressure.

## Ice Machine Electric

115/60/1. (208-230/60/1 and 230/50/1 also available, consult factory.)

**Minimum circuit ampacity:** Air-cooled: 16.2 amps  
Water-cooled: 15.5 amps  
Remote: 17.9 amps

**Maximum fuse size:** Air, Water, and Remote-cooled: 20 amps

HACR-type circuit breakers can be used in place of fuses.

## Specifications

**BTU Per Hour:**  
7,800 (average) 9,600 (peak)

**Compressor:**  
Nominal rating: 3/4 HP

**Refrigerant:** R404A

**Cupra-Nickel Condenser:**  
(Water-cooled models)  
Adds protection from  
corrosive water elements.

### Operating Limits:

- **Ambient Temperature Range:**  
45°-110°F (7.2°-43.3°C)  
Remote: -20° to 120°F  
(-29° to 49°C)
- **Water Temperature Range:**  
45°-90°F (7.2°-32.2°C)
- **Water Pressure Ice Maker Water In:**  
Min. 20 psi (137.9 kPa)  
Max. 80 psi (551.1 kPa)

## Ice Shape

Small nugget SoftQube™ ice is approximately 3/10" x 3/10" x 1/2" (8 x 8 x 12 mm) with a softer, chewable texture while still providing maximum cooling effect.



## SN-650 on B-420 Storage Bin

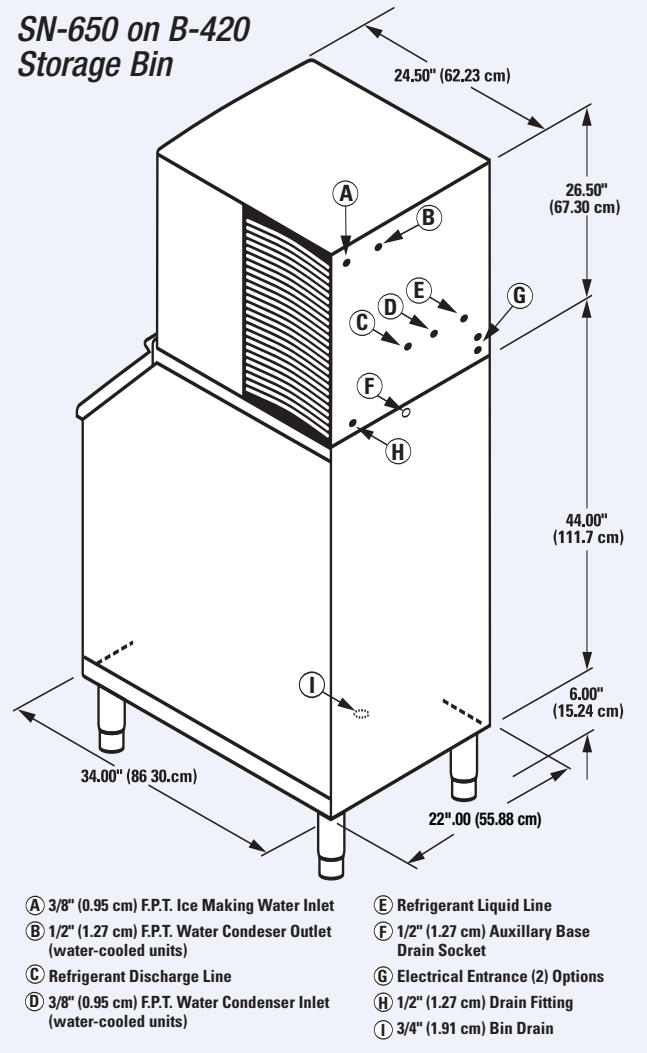

### Installation Note -

Minimum installation clearance— Top/sides: 8" (20.32 cm); Back: is 5" (12.7 cm).

### Dispenser Note -

Verify with the dispenser manufacturer that the correct agitator and deflector kit for nugget ice dispensing is included with your dispenser purchase.

©2005 Manitowoc 2106 Continuing product improvement may necessitate change of specifications without notice. 3447A

MANITOWOC ICE, INC.  
2110 South 26th Street, P.O. Box 1720  
Manitowoc, WI 54221-1720, USA  
Ph: 920-682-0161 • Fax: 920-683-7589  
Visit us online at [www.manitowocice.com](http://www.manitowocice.com)

