

Project:

Quantity:

Item #:

Model Specified:

TURBO AIR'S GLASS DOOR MERCHANDISER

One Door Models

CABINET INTERIOR/EXTERIOR SPECIFICATIONS



Refrigerator TGM-5R • TGM-11R

Turbo Air's freshly refined design maximizes the display effect. Cabinet interior including sides, bottom, back and top are made of ABS sheet. Exterior cabinet including sides and top are PCM with black color and back is SPG(TGM-5R). Exterior cabinet sides are EGI+powder painting and back and top are lamina sheet with white color(TGM-11R).

• Hardware, Insulation and Construction

Our products keep a stable temperature throughout the unit, even under heavy use.

Inside temperature is controlled automatically.

Cabinet body is insulated with 100% foamed-in-place polyurethane foam insulation.

Product comes with adjustable legs.

• Door system

A double pane glass with a patented, transparent and thermal insulating film is applied.

The double pane glass weighs less than a triple pane glass. This means less overall door maintenance compared with a triple pane glass.

• Shelving

Fully adjustable wire shelves are made of heavy gauge metal wire with non-corrosive coating.

• Standard Features

- Black color cabinet.(Only TGM-5R)
- White color cabinet.(Only TGM-11R)
- Black color frame of door.
- Double pane glass doors with thermal film.
- Fully adjustable wire shelves with non-corrosive coating.
- A fluorescent light for interior display.
- Adjustable leg for stable installation.

• Option

- Gravity feed merchandising racks.
- Customized graphics.
- Customized Color. (Available in Quantity)



LISTED
COMMERCIAL
REFRIGERATOR
AND/OR FREEZER
43BK



ISO9001



1250 Victoria St. CARSON, CA 90746

U.S.A & Canada Toll Free (800)627-0032 www.turboairinc.com

Project:	Quantity:	Item #:
Model Specified:		

One Door Models

(Unit : inch)

CABINET INTERIOR/EXTERIOR SPECIFICATIONS

MODEL	TGM-11R	TGM-5R
Exterior Dimensions(in)	23.6 x 24.8 x 63.7	18.9 x 23.6 x 33.7(LxDxH)
Compressor	1/4 HP	1/10 HP
Range of Temperature	33°F~50°F	33°F~50°F
Shelves	4 EA	3 EA
Power Voltage	115V/60Hz	115V/60Hz
Power Cord Length	5.5 ft	6.4 ft
Plug-in installation	NEMA 5-15p	NEMA 5-15p
Net Weight	137 lbs	75 lbs
Weight after packing	174.2 lbs	79.4 lbs
AMP	5.4 A	2.2 A
Interior Dimension(in)	19.0 x 19.7 x 44.7	16.1 x 20.0 x 29.2(LxDxH)
Shelf size	20.2 x 14.5	A : 16.1 x 14.3 B : 16.1 x 15.7 C : 16.1 x 9.1

**Design and specifications can be changed without prior notice for product improvement.*

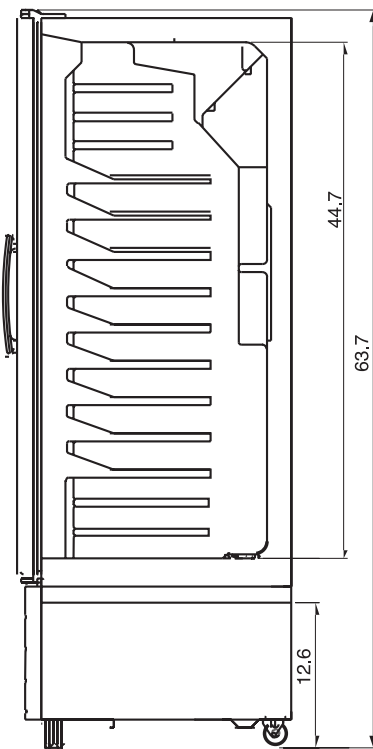

TGM-11R SIDE VIEW

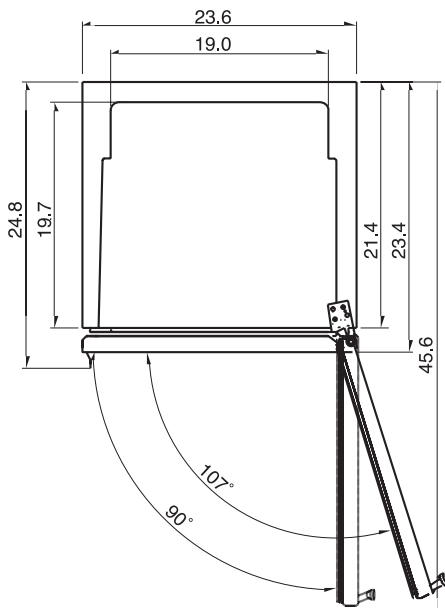

TGM-11R PLAN VIEW

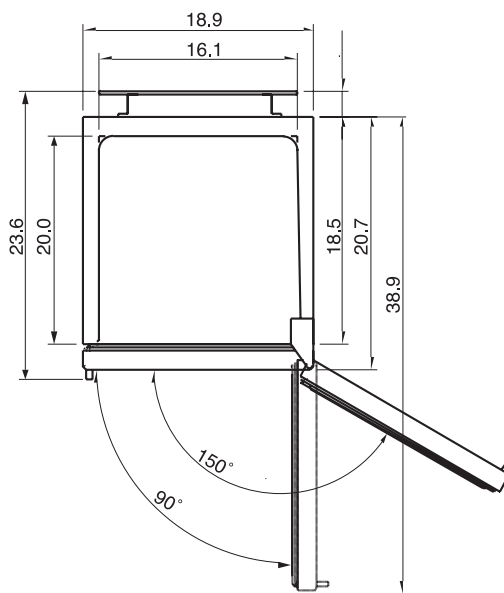

TGM-5R PLAN VIEW

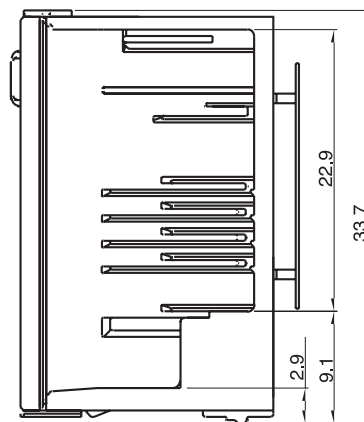

TGM-5R SIDE VIEW