

Worktop Refrigerators

Exceptional Quality 2 Years Parts and Labor Warranty



FEATURES / BENEFITS

■ **EFFICIENT REFRIGERATION SYSTEM**

Turbo Air's solid door refrigerators are designed with oversized and balanced (CFC Free R-134A) refrigeration systems. These include efficient evaporators and condensers for faster cooling and greater efficiency.

■ **STAINLESS STEEL LOUVER**

Stainless steel louvers ensure even distribution of cold air throughout the interior of the unit. Built to withstand food acids and stains.

■ **STAINLESS STEEL CABINET CONSTRUCTION**

The Turbo Air Super Deluxe model boasts a stainless steel interior and exterior (except the back). It guarantees the utmost in cleanliness and long product life. The Super Deluxe can add a touch of style to the most refined setting.

■ **HIGH-DENSITY POLYURETHANE INSULATION**

The entire cabinet structure and solid doors are formed-in-place using high density, CFC free polyurethane insulation.

■ **STURDY, CLEAN STAINLESS SHELVING**

Shelves are the most important part of cleanliness as they come in direct contact with food. After a while, PVC coated wire shelves may peel, rust and lead to unsanitary conditions. Only the Turbo Air Super Deluxe series uniquely provides stainless shelving.

■ **ERGONOMICALLY DESIGNED DOOR**

Customers' fatigue fades away with easy grip handles and doors that open effortlessly. These features along with self-closing doors make this the ultimate choice in customer convenience. ABS sheet door liners resist water condensation with thermal efficiency.

■ **MAGNETIC DOOR GASKET**

Magnetic door gaskets are of one piece construction, removable without tools for ease of cleaning and replacement.

■ **HOT GAS CONDENSATE SYSTEM**

Through Turbo Air's creative innovation, the condensate system surfaces have been specially treated to resist corrosion. This not only increases efficiency without the risk refrigerant leakage from corrosion, but also prevents the overflow of condensate water.

■ **REFRIGERATOR HOLDS 33°F ~ 38°F FOR THE BEST IN FOOD PRESERVATION**

* Height does not include 6" for caster height.

Model	Swing Door	CU./FT.	#of Shelves	HP	AMPS	Crated Weight	L D H
TWR-28SD	1	7	1	1/3	6.6	175	27 1/2 x 30 x 33 1/2
TWR-36SD	2	11	2	1/3	6.6	200	36 1/3 x 30 x 33 1/2
TWR-48SD	2	12	2	1/3	6.5	253	48 2/9 x 30 x 33 1/2
TWR-60SD	2	16	2	1/3	8.9	275	60 1/4 x 30 x 33 1/2
TWR-72SD	3	19	3	1/2	9.9	363	72 2/3 x 30 x 33 1/2

TWR-28SD / TWR-36SD / TWR-48SD / TWR-60SD / TWR-72SD SPECIFICATIONS

MODEL	TWR-28SD	TWR-36SD	TWR-48SD	TWR-60SD	TWR-72SD
Exterior Dimension (LxDxH)	27 1/2x30x33 1/2	36 1/3x30x33 1/2	48 2/9x30x33 1/2	60 1/4x30x33 1/2	72 2/3x30x33 1/2
Cubic Feet	7	11	12	16	19
Compressor (HP)	1/3	1/3	1/3	1/3	1/2
Shelves	1ea	2ea	2ea	2ea	3ea
Net Weight	150lbs	179lbs	221lbs	262lbs	306lbs
Voltage (i) NEMA-5-15P	(i) 115V / 60Hz	(i) 115V / 60Hz	(i) 115V / 60Hz	(i) 115V / 60Hz	(i) 115V / 60Hz
Amp	6.6 A	6.6 A	6.5 A	8.9 A	9.9 A
Cord Length	9.2 ft.	9.2 ft.	9.2 ft.	9.2 ft.	9.2 ft.
Plug-In	NEMA 5-15P	NEMA 5-15P	NEMA 5-15P	NEMA 5-15P	NEMA 5-15P

- **SELF-CONTAINED SYSTEM**
- **5" SWIVEL CASTERS**
- **LEGS AVAILABLE FOR ALL MODELS (OPTION)**
- **REMOTE CABINETS AND CONDENSING UNITS AVAILABLE FOR ALL MODELS.**

*Design and specifications subject to change without notice.

- **WARRANTY : 2 Years Labor and Parts Warranty
Additional 3 Years Warranty on Compressor**



LISTED COMMERCIAL REFRIGERATOR AND/OR FREEZER 438K



(unit : inch)

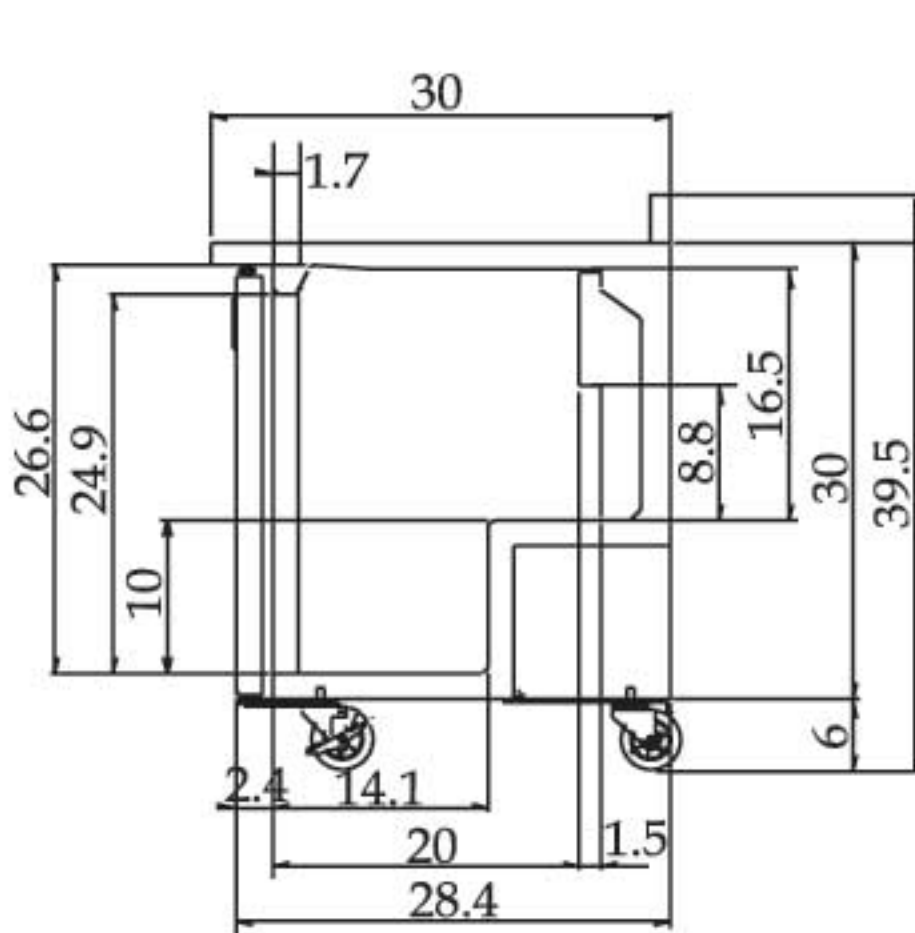

SIDE VIEW

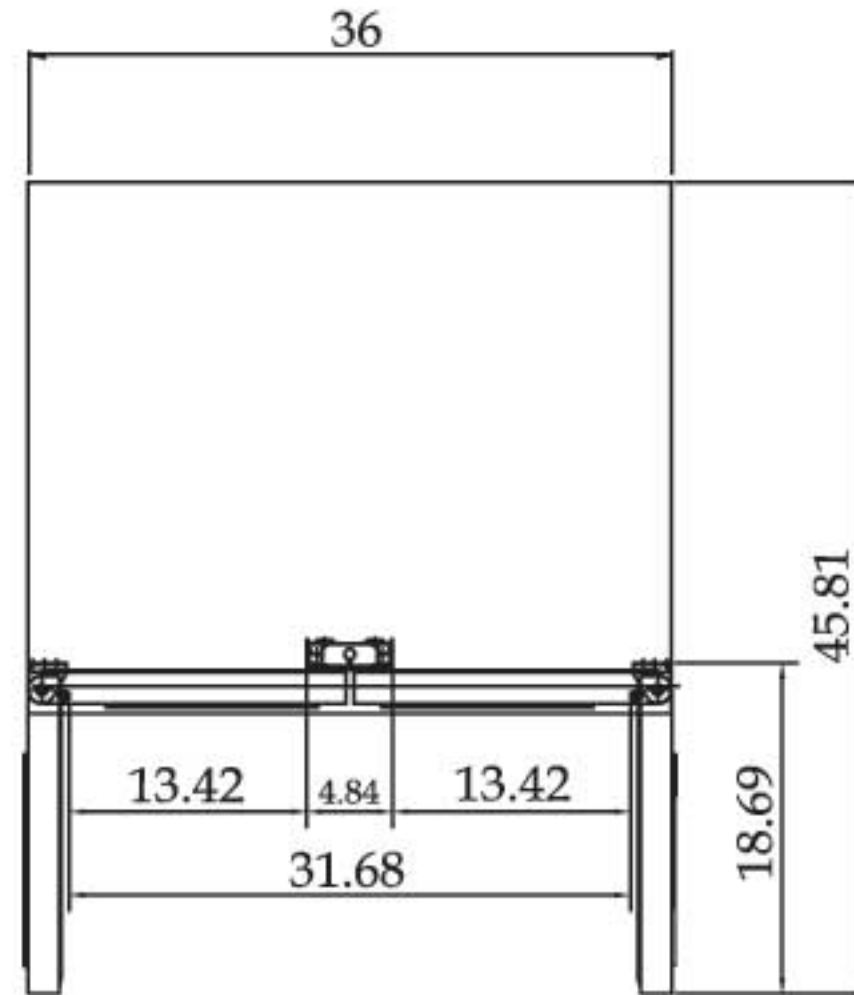

TWR-36SD PLAN VIEW

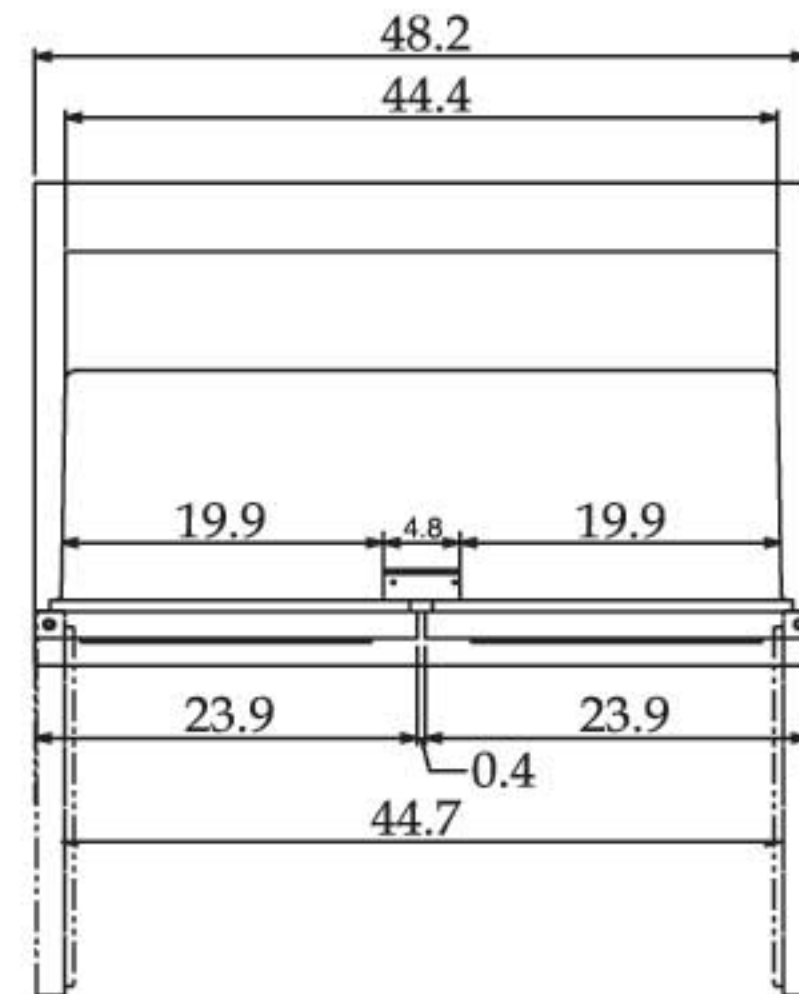

TWR-48SD PLAN VIEW

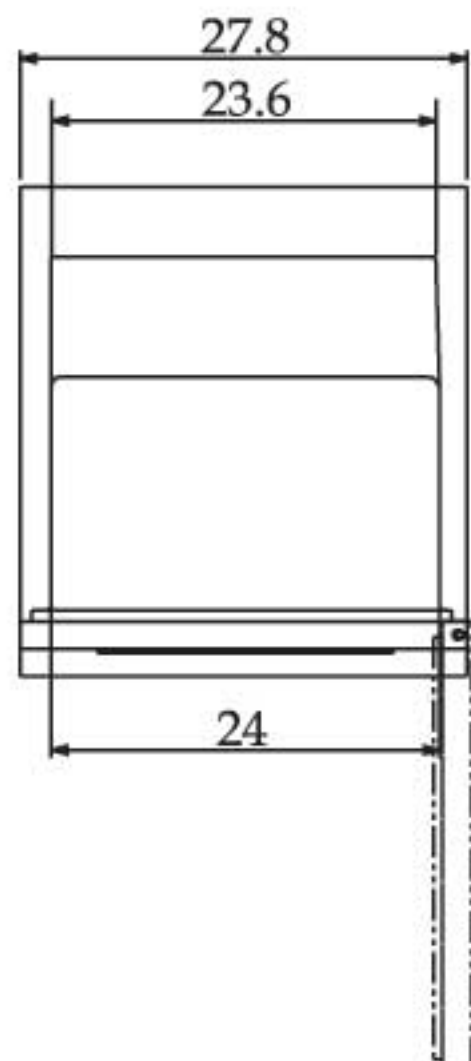

TWR-28SD PLAN VIEW

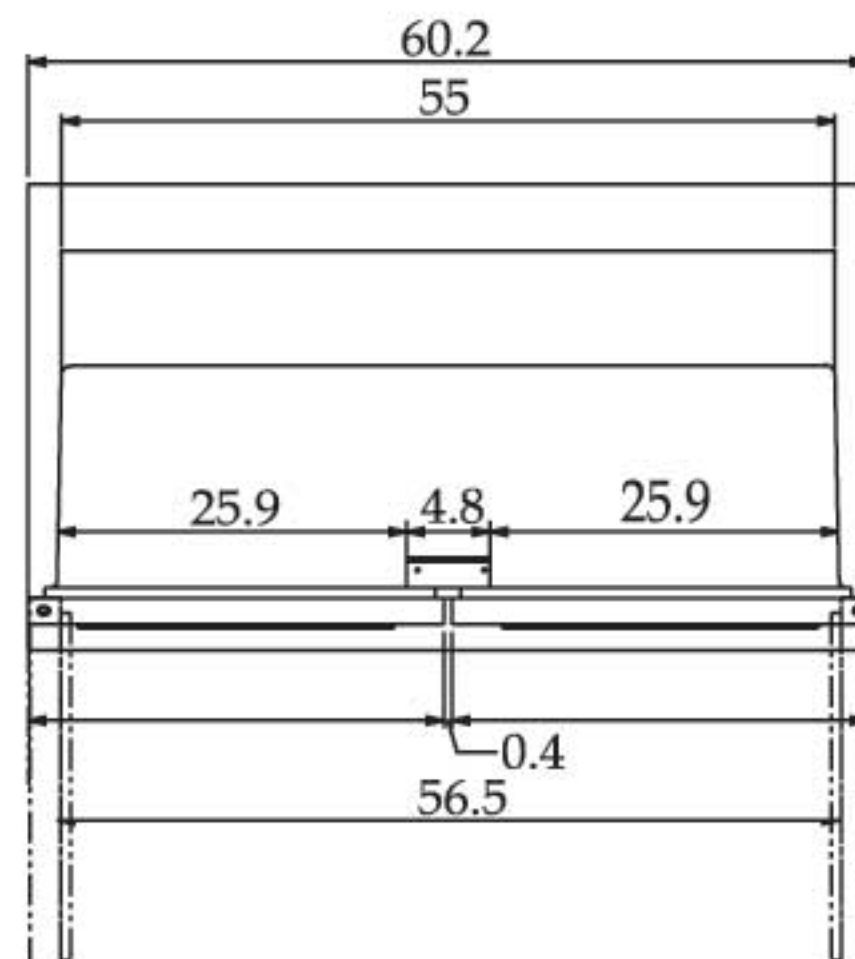

TWR-60SD PLAN VIEW

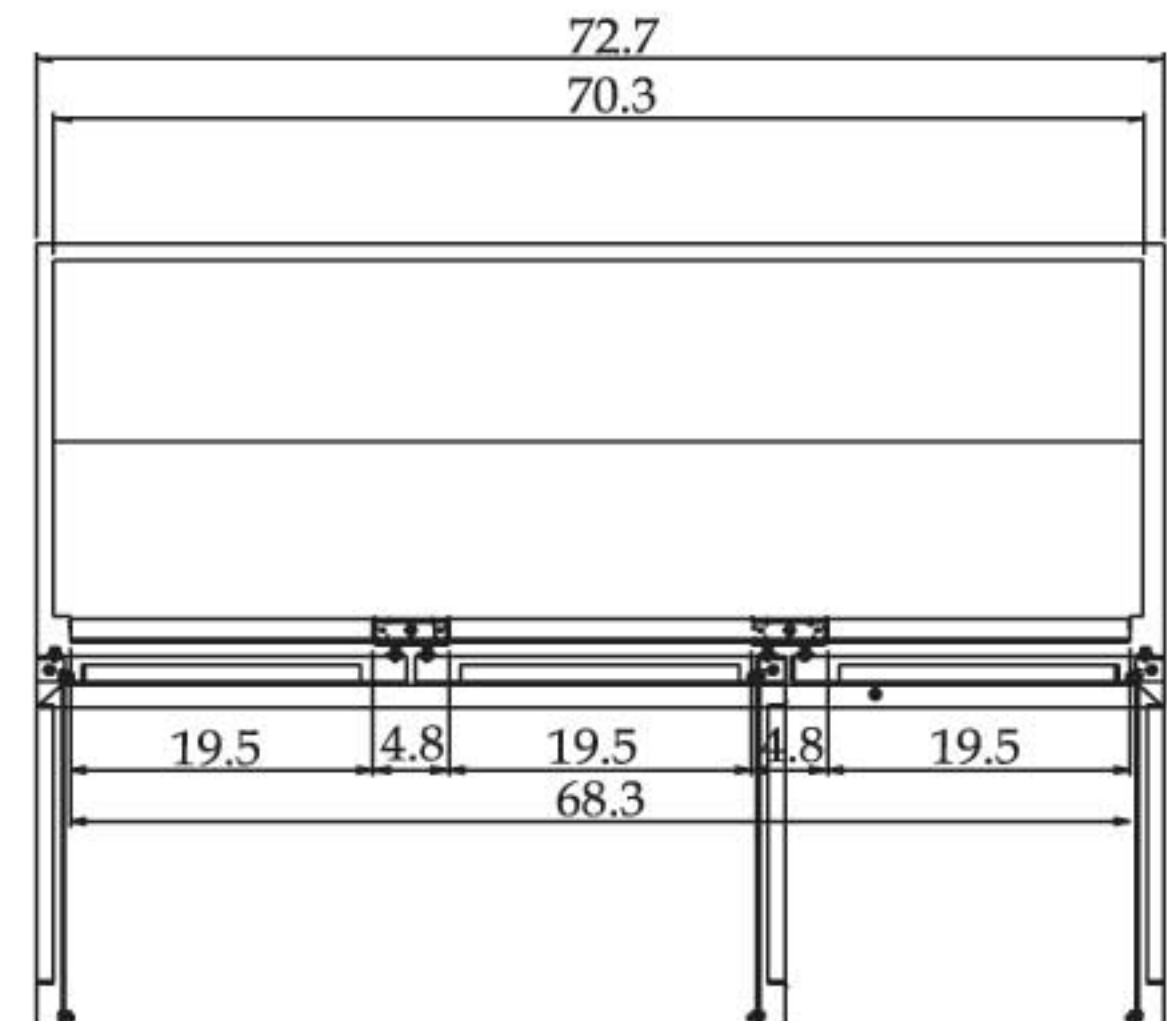

TWR-72SD PLAN VIEW