

OPEN DISPLAY MERCHANDISERS

All 300 series stainless steel interior including Back Wall, Shelves, Floor.

Stainless steel shelves that are adjustable in 1" increments.

Self-Contained System.

Two position shelving standard

Perforated interior back wall and top for better air flow

Electronic Control allows to easily monitor and adjust many functions.

Front air intake and rear air discharge.

Oversized refrigeration(R404A).

Holds 33°F to 38°F.



TURBO AIR REFRIGERATOR MANUFACTURER
Turbo air

1250 Victoria St. Carson, CA 90746

U.S.A & Canada Toll Free (800)627-0032 www.turboairinc.com

OPEN DISPLAY MERCHANDISERS



SPECIFICATIONS

MODEL	TOM - 40	TOM - 50
EXTERIOR DIMENSIONS(LxDxH)	38.4 x 26.9 x 78	50.4 x 26.9 x 78
INTERIOR DIMENSIONS(LxDxH)	36 x 14 x 49.4	48 x 14 x 49.4
COMPRESSOR	1HP	1HP
RANGE OF TEMPERATURE	33°F ~ 38°F	33°F ~ 38°F
POWER VOLTAGE	115V 60Hz	115V 60Hz
PLUG-IN INSTALLATION	NEMA5-15p	NEMA5-15p
AMP	15A	15A
SHELVES	3EA	3EA
SHELF SIZE	□ 35.8 x 10.8	□ 47.8 x 10.8
	□ _E 35.8 x 11.8	□ _E 47.8 x 11.8
	□ _Ø 35.8 x 12.8	□ _Ø 47.8 x 12.8
NET WEIGHT(lbs)	507	573
WEIGHT AFTER PACKING(lbs)	516	584

(Unit : inch)

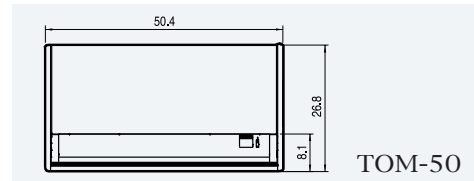
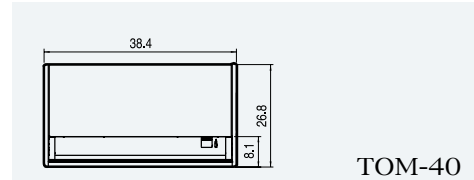

TOM-40

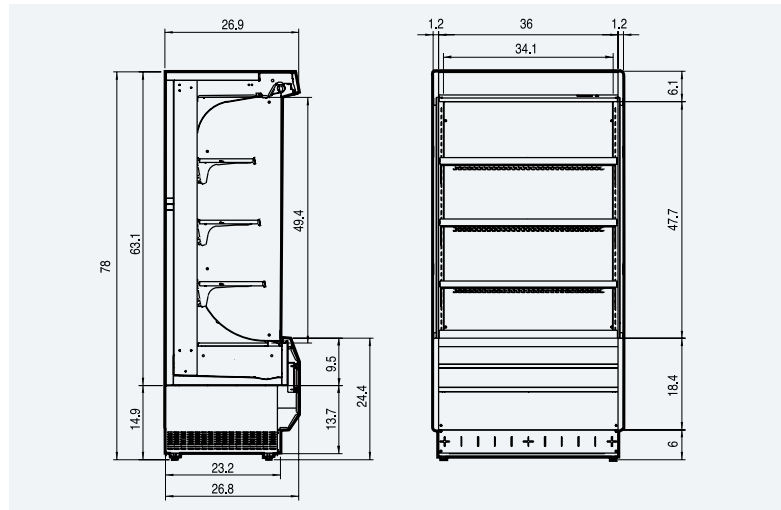

TOM-50

